

A Practical Guide to Blown Film Troubleshooting

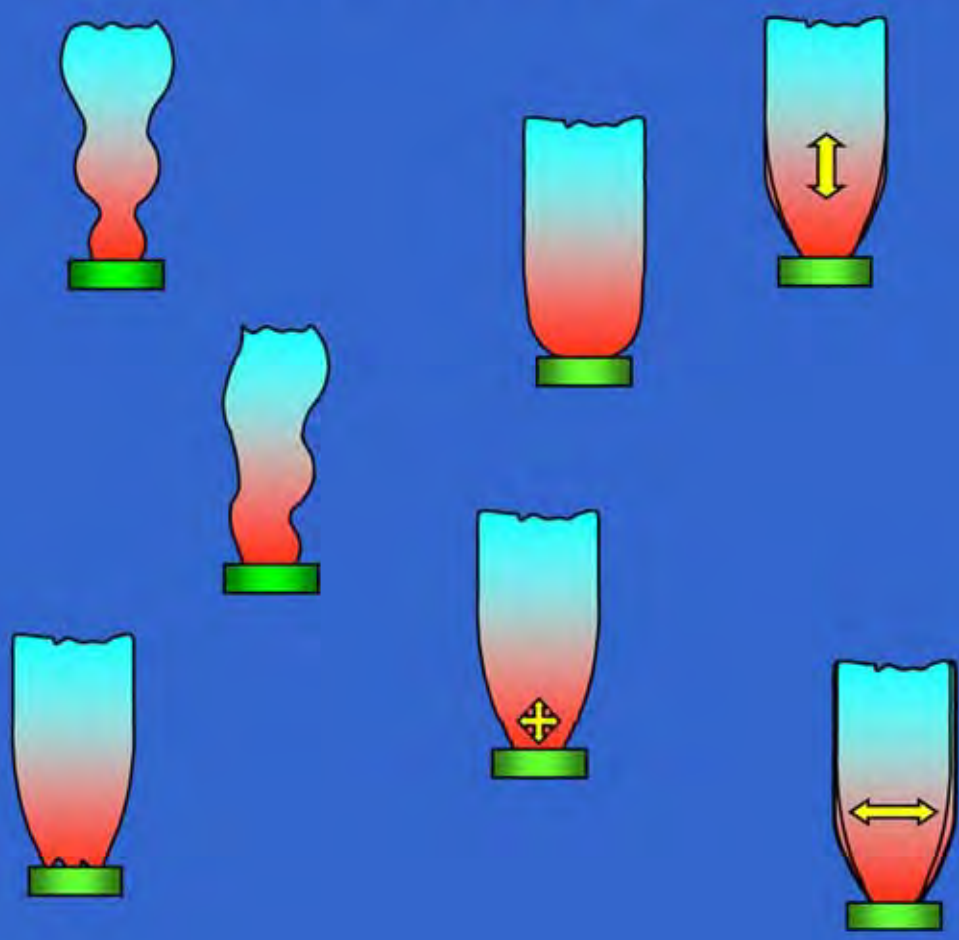

Plastics Touchpoint Group, Inc.

Paul Waller

Table of Contents

| | | |
|-----------|--|-----|
| Chapter 1 | Polymer Properties and Terminology | 1 |
| Chapter 2 | Feeding Systems to Gearboxes | 18 |
| Chapter 3 | Extruder Screws and Set-up | 29 |
| Chapter 4 | Temperature Controllers to Screen Changers | 51 |
| Chapter 5 | Blown Film Dies | 65 |
| Chapter 6 | Bubble Cooling | 93 |
| Chapter 7 | Bubble Collapsing | 119 |
| Chapter 8 | Post Extrusion Operations | 129 |
| Chapter 9 | Troubleshooting Techniques | 161 |
| | Film Defects Troubleshooting Guide | 167 |
| | Roll Defects Troubleshooting Guide | 184 |
| | Glossary of Terminology | 191 |
| | Subject Index | 221 |

About the Author



Paul Waller, P.Eng., MBA, Cert.P.P.
President
Plastics Touchpoint Group, Inc.
Website: www.plasticstouchpoint.com
E-mail: paul@plasticstouchpoint.com
Phone: (001) 416-788-9742
Skype: paul_waller1

Plastics Touchpoint Group, Inc. was established to meet the growing demand for expertise in the flexible packaging industry. The company focus is on blown and cast film extrusion and film conversion operations. Plastics Touchpoint has worked with clients throughout North America, South America, the Middle East, Africa, Australia and Asia. Clients include raw material suppliers, processors, end users, educational institutions and industry associations.

Paul Waller is a frequent presenter and trainer at conventions and professional functions as well as a prolific writer. He designed and delivered the Blown Film Technology Program for the Canadian Plastics Training Centre in Toronto, Canada and SENAI in Brazil. Mr. Waller has provided intensive in-house training to more than 1,000 operators, technicians and engineers. He has taught film troubleshooting seminars on five continents and is the first candidate to be awarded the Certified Plastics Practitioner designation for Blown Film Extrusion by the Canadian Plastics Sector Council.

Mr. Waller is a Professional Engineer licensed in the province of Ontario, Canada. He is an Honored Service Member of the Society of Plastics Engineers (SPE), Councilor and past President of the Ontario section of SPE, Secretary and Chair-Elect of the Flexible Packaging division of SPE, co-chair of the Canadian Plastics Sector Council, a member of the Canadian Plastics Industry Association and the Canadian Plastics Pioneers.’

Bulk Conveying System Fundamentals

The most common bulk unloading system is the pull push system. A blower attached to the bulk hopper truck sucks resin from the truck and blows it into a silo. Changes in diameter of the pipe can affect the velocity and friction applied to the surface of the pellets. A description of the Venturi effect is illustrated in the following diagram.

Bulk Conveying Venturi Effect

When a fluid flows through a constricted area, its speed increases and the pressure decreases.

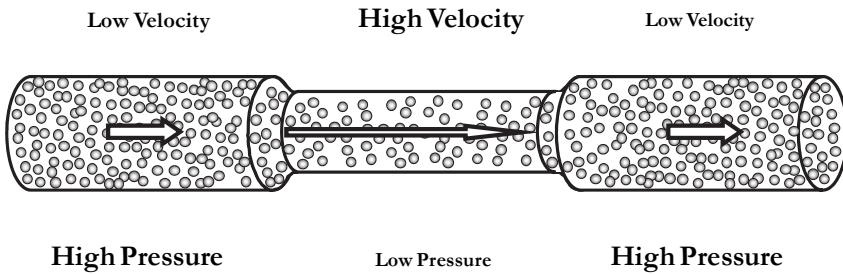

Dust from Bulk Conveying Systems

Dust or “fines” are created when the friction on the surface of the pellets is too high. Some dust is present in resin pellets when it arrives from the raw material supplier. Bulk transfer systems must have filters to remove this material because it can cause blockages in the transfer pipes and clog extruder throats.

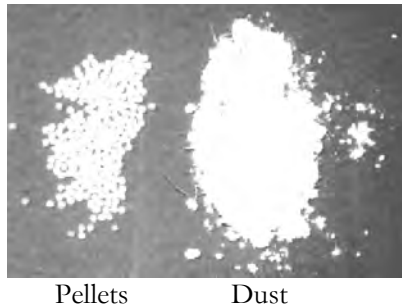

Misconceptions about Bulk Conveying Systems

Fluff and Angle Hair

Velocity actually *increases* as pressure *decreases* because air inside transfer pipe expands and accelerates the transfer rate. High transfer rates cause excessive friction along smooth internal surfaces of the pipes. Pieces of the pellets are break off and fuse to form small diameter filaments known as angle hair. Slip and other migrating additives tend to concentrate on the surface of the pellets. Since these filaments are formed from the exterior of the pellets, they tend to have much higher concentrations of these additives than the average pellet.

Effect of Drag and Pressure Flow on Velocity Profile

When combined, the illustration shown below indicates that melted polymer near the screw surface flows backwards, whereas melted polymer near the barrel wall moves forward. The result is a pattern of recirculating flow inside the screw channel.

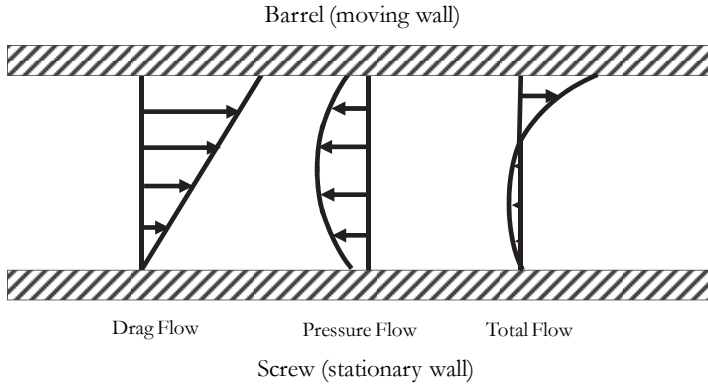

Leakage Flow

Leakage flow is the amount of melted polymer that squeezes between the top of the screw flight and the barrel wall, moving backwards along the screw. This was referred to as the Zap Gap in previous illustrations. Leakage flow is the least important of the three factors unless the screw or barrel is worn out. Optimal clearance between the screw and barrel depend on the diameter of the screw.

Net Melt Conveying Flow (Total Flow)

The recirculating flow closer to the screw reduces overall output. The total flow is illustrated in the following three-dimensional diagram.

Recirculating Flow

Forward Flow

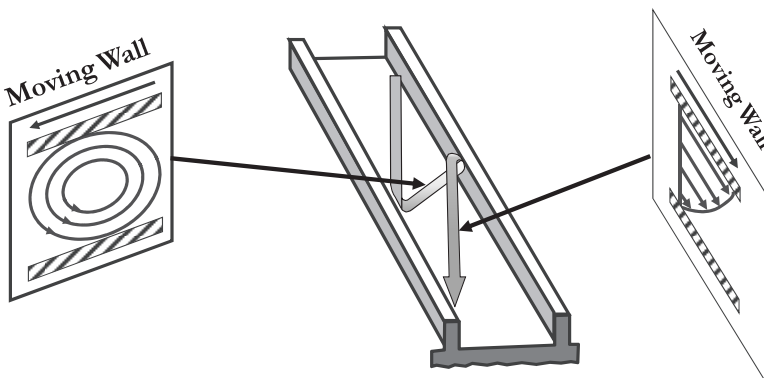

Assuming the extruder motor and drive are stable, surging can be analyzed by monitoring the following operating parameters.

Three parameters increase and decrease, just like in a chorus line of dancers:

Extruder
Motor Amps



Extruder
Backpressure



Frost Line
Height



- Extruder motor amperage
- Extruder back pressure
- Frost line height
- All 3 parameters increase and decrease in cycles
- Cycles are not always synchronized

Symptoms of Solids Conveying Variations in Feed Zone

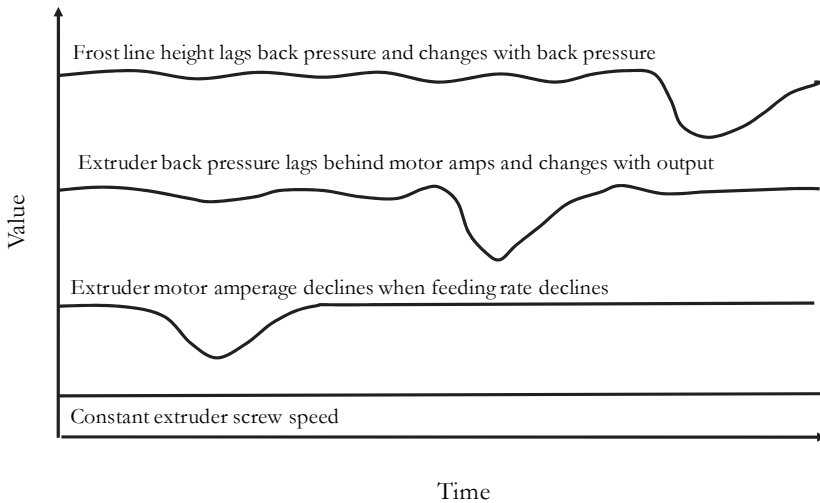

Strategies to Avoid Solids Conveying Variations in Feed Zone

- | | |
|-----------------------|---|
| Processing Conditions | <ul style="list-style-type: none"> • Keep feed throat cool • Use water cooling, if available, to cool screw in feed zone |
| Equipment | <ul style="list-style-type: none"> • Remove blockages from feed throat • Ensure that vacuum loaders can supply sufficient resin to feed hopper • Maintain at least 60 cm (2 ft) of resin in the hopper to avoid starving the screw |

Melt fracture becomes transparent



Interfacial instability remains hazy



Water

Gels

Gels are classified first by size and distribution pattern, and then by shape and color. They include pinpoint (very small), arrowhead, chevron, V or J, fisheye, platelet or disc, lens (hollow) and discolored gels. Gels that are evenly dispersed throughout the film are likely to come from the raw material or extruder. Gels that form lanes of gel and gel-free regions in the machine direction are likely to be created inside the die.

The size of the gel compared to the film gauge defines the severity of the problem. Gels that are smaller than 5 microns will affect appearance but are not likely to result in mechanical failure of the film. As gels become larger, they become more unappealing and may result in mechanical failure of the film. The standard test methods for reporting gels only report the quantity larger than specific sizes. These include ASTM D-3351 for gels greater than 400 microns and the TAPPI Dirt Chart T-437 for black specs. Automatic gel counters are available, but are very expensive.

Unmelted Gels

Very small gels evenly dispersed throughout the film are often referred to as applesauce. Larger unmelts can deform enough to flow through screen packs and reform on the downstream side. The primary cause for unmelts is insufficient mixing in the extruder to complete the melting process.

Applesauce



Unmelt



Air Ring Control (Locking) Points

One style of single lip and three distinct styles of dual lip air rings are commonly available. The Venturi effect between the bubble and the air ring surfaces can be adjusted by changing air velocity at specific points. Illustrations of the “control” or “locking” points are illustrated as circles on the cross sections of these styles of air rings below.

Single lip

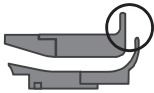

Dual lip with iris

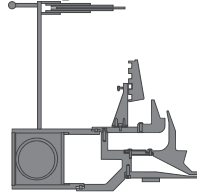

Dual lip with perforated ring

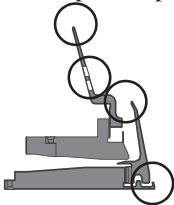

Dual lip with stabilizer rings

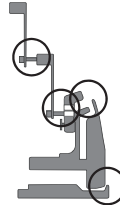

Manipulation of Air Ring Control (Locking) Points

Adjustments and the affect of air volume delivered by the air ring or Internal Bubble Cooling (IBC), if available, are described in the illustration below.

Single lip

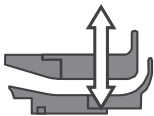

Increase or decrease Air Ring blower speed to change venturi effect and frost line height

Dual lip with iris

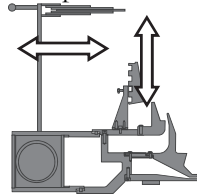

Dual lip with perforated ring

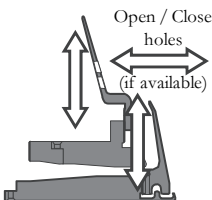

Open / Close holes (if available)

Increase or decrease IBC cooling rate (if available) to change melt strength and frost line height

Dual lip with stabilizer rings

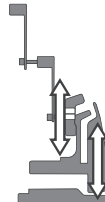

Wrinkles

Edge guides, misaligned rollers and improper tension can result in many types of wrinkles. Roller misalignment patterns can be eliminated using the following strategies. The objective is to keep to the left of the solid curved line shown below by adjusting tension or shifting the boundary between the wrinkle and no wrinkle zones.

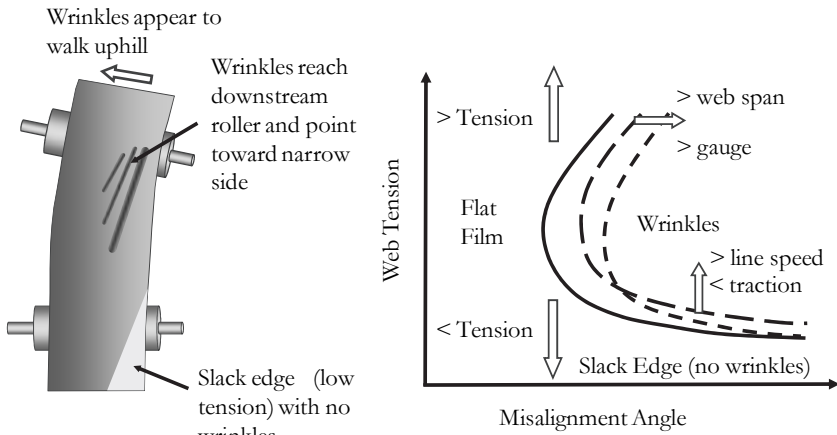

Wrinkles are an indication of gauge variation or unstable tension control. The patterns can be summarized as *machine direction* and *diagonal* wrinkles.

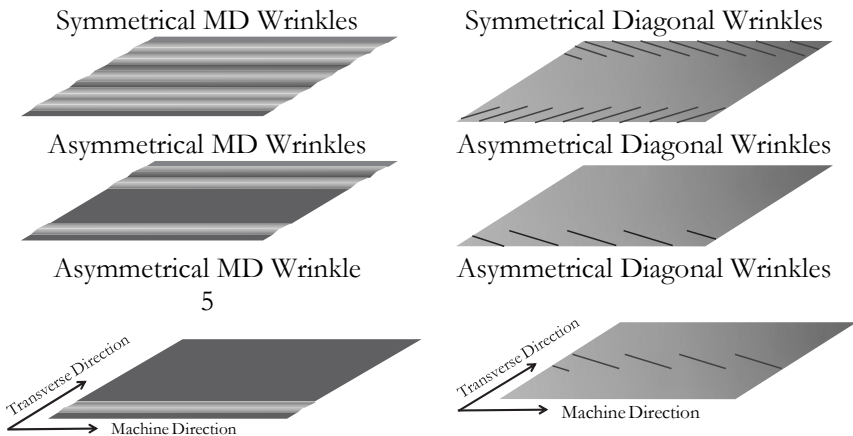

Buckled Rolls

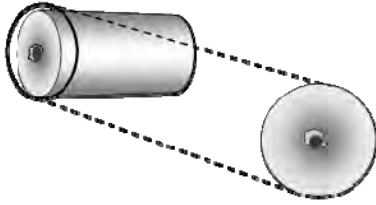

Buckled rolls usually result in crushed cores. It is often impossible to remove the roll and the film must be cut off in order to relieve the pressure.

Solutions for Buckled Rolls

- | | |
|-----------------------|---|
| Processing Conditions | <ul style="list-style-type: none"> • Reduce film tension at winder • Reduce film temperature (shrinks onto core as film cools down) • Increase taper tension • Reduce lay-on roller pressure at winder (crushed core) |
| Equipment | <ul style="list-style-type: none"> • Align cores to edge of film (web overhang can crush core on one side) |

Tapered Rolls

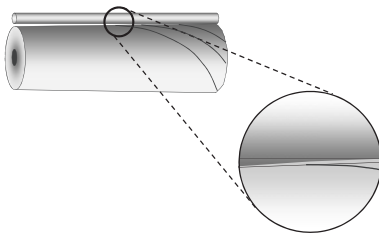

These rolls are smaller in diameter at one end and gradually increase in diameter along the face of the roll. A gauge difference of 0.5 microns (0.02 mils) will result in large diameter differences as the roll builds up. The illustration below shows the affect of this difference across the roll face.

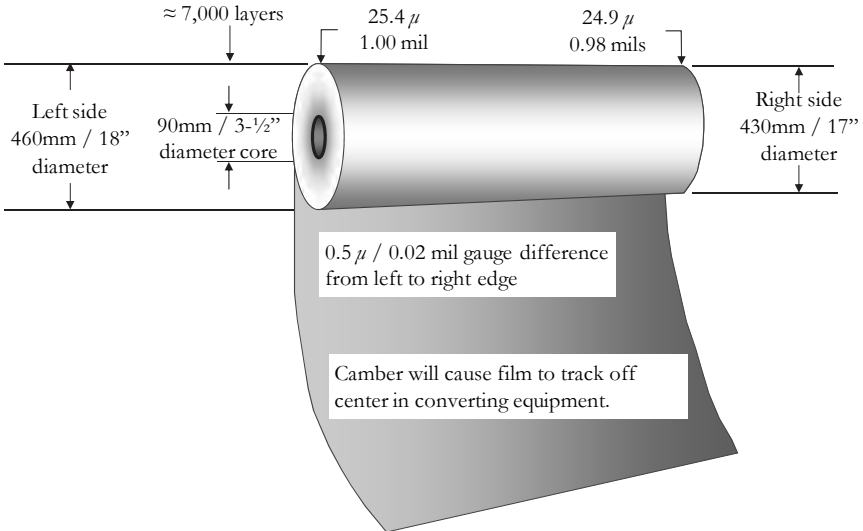

Small problems become magnified as the bubble expands and becomes thinner below the frost line. The symmetrical patterns overlap with non-symmetrical ones, resulting in unusual bubble shapes and gauge bands. An example of how thin gauge bands at 90° interval around the bubble affect its shape is shown in the following illustration.

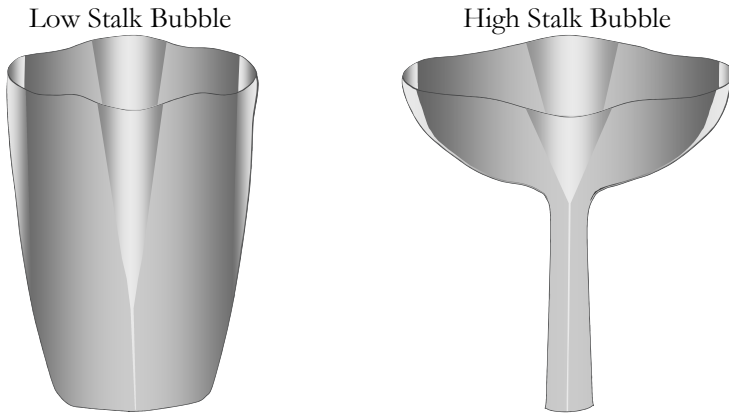

Some common equipment problems are illustrated in the following examples.

Effect of a Misaligned Air Ring

| Die Position | Gauge Profile |
|--------------|------------------------|
| A | 41.9 μ / 1.65 mils |
| | 41.4 μ / 1.63 mils |
| | 40.4 μ / 1.59 mils |
| B | 38.9 μ / 1.53 mils |
| | 38.9 μ / 1.50 mils |
| | 34.3 μ / 1.35 mils |
| C | 33.0 μ / 1.30 mils |
| | 34.8 μ / 1.37 mils |
| | 37.3 μ / 1.47 mils |
| D | 38.4 μ / 1.51 mils |
| | 39.9 μ / 1.57 mils |
| | 41.1 μ / 1.62 mils |
| A | 41.9 μ / 1.65 mils |

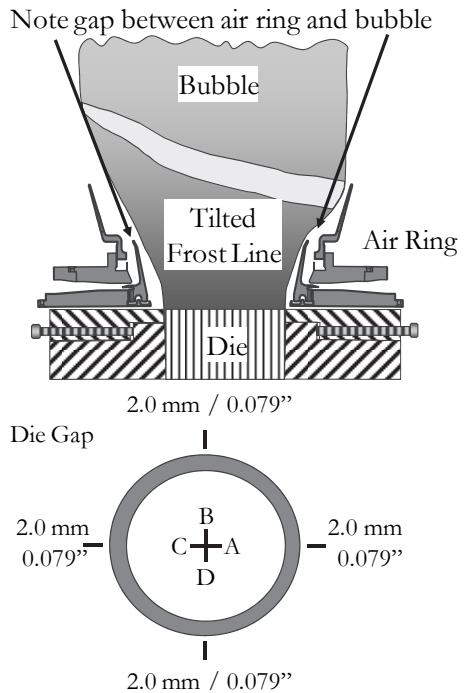

The following guide summarizes the troubleshooting tips described in the manual. The blown film line is split into several zones to remind operators which area of the line should be examined when problems occur. Each problem includes causes split into raw material, processing conditions and equipment. Recommendations for each cause are included.

Blown Film Troubleshooting Guide Index

| | |
|---|-----|
| Blown Film Troubleshooting Guide Index | 163 |
| Blown Film Properties | 165 |
| Blow Film Troubleshooting Guide Diagram | 166 |

Film Defects Troubleshooting Guide

| | |
|--|-----|
| Blocking | 167 |
| Die lines, weld lines (MD) | 168 |
| Gels -Apple sauce (very small gels) | 168 |
| Gels - Arrow heads, chevrons (“V” or “J”) | 169 |
| Gels - Discol-ored | 170 |
| Gels - Fisheye, platelet, disc | 170 |
| Gels – Hollow or Void | 171 |
| Low gloss, high haze, low clarity | 172 |
| Low heat seal strength | 172 |
| MD gauge variation | 173 |
| Melt fracture and shark skin | 175 |
| Interfacial instability - short wave pattern | 175 |
| Interfacial instability - short and long wave patterns | 176 |
| Port lines | 176 |
| Poor surface treatment | 176 |
| Scratches (MD) | 177 |
| Splitty film (low MD tear strength) | 177 |
| Streaks in MD | 178 |
| Streaks in TD | 178 |
| TD gauge variation | 179 |
| Uneven film or sheet width | 181 |
| Uneven gussets | 182 |
| Weak edge folds | 182 |
| Wrong color | 183 |

Roll Defects Troubleshooting Guide

| | |
|--------------------------------------|-----|
| Baggy edges | 184 |
| Buckled rolls | 184 |
| Bumpy rolls (Tin Canning) | 184 |
| Folds, creases | 185 |
| Non uniform surface hardness | 185 |
| Ringed rolls (fuzzy edges) | 185 |
| Roll too hard | 186 |
| Roll too soft | 186 |
| Sag in film (soft in middle of roll) | 186 |
| Starred rolls or crushed cores | 187 |
| Tapered, convex or concave rolls | 187 |
| Telescoped rolls | 188 |
| Uneven roll width | 188 |
| Wrinkles in roll | 189 |



Published by:
Plastics Touchpoint Group, Inc.

Website:
www.plasticstouchpoint.com

This book is designed to help readers understand how the complex interaction of raw materials, equipment and processing conditions affect productivity and film characteristics.

Contents include:

- Raw material characteristics**
- Equipment options and comparisons**
- Glossary of terminology**
- Troubleshooting guides for:**
 - Extruder temperature profiles**
 - Screw wear**
 - Surging**
 - Melt fracture**
 - Interfacial instability**
 - Gels**
 - Bubble instability**
 - Surface treatment**
 - Wrinkles**
 - Roll geometry**
 - Heat sealing**
 - Gauge variation**

